

Submittal

**2.0 Ton
Variable Speed Convertible Air Handler
A4AH6V24A1B30A**

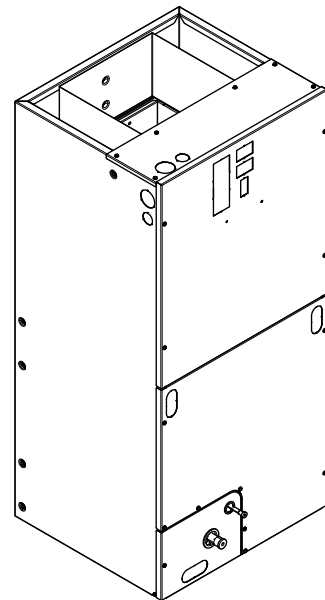

Product Specifications

MODEL	A4AH6V24A1B30A
RATED VOLTS/PH/HZ	208-230/1/60
RATINGS^(a)	See O.D. Specifications
INDOOR COIL — Type	Plate Fin
Rows — F.P.I.	4 - 14
Face Area (sq. ft.)	3.44
Tube Size (in.)	3/8
Refrigerant Control	TXV
Drain Conn. Size (in.) ^(b)	3/4 NPT
DUCT CONNECTIONS	See Outline Drawing
INDOOR FAN — Type	Centrifugal
Diameter-Width (In.)	11 X 8
No. Used	1
Drive - No. Speeds	Direct - 16
CFM vs. in. w.g.	See Fan Performance Table
No. Motors — H.P.	1 - 1/3
Motor Speed R.P.M.	Variable
Volts/Ph/Hz	208-230/1/60

F.L. Amps	2.5
FILTER	
Filter Furnished? ^(c)	No
REFRIGERANT	R-410A
Ref. Line Connections	Brazed
Coupling or Conn. Size — in. Gas	3/4
Coupling or Conn. Size — in. Liq.	3/8
DIMENSIONS	H x W x D
Crated (In.)	48-1/4 x 22-1/2 x 25-1/2
Uncrated	46-3/4 x 18-1/2 x 21-1/8
WEIGHT	
Shipping (Lbs.) / Net (Lbs.)	126/117

^(a) These Air Handlers are A.H.R.I certified with various Split System Air Conditioners and Heat Pumps (AHRI STANDARD 210/240). Refer to the Split System Outdoor Unit Product Data Guides for performance data.

^(b) 3/4" Male Plastic Pipe (Ref: ASTM 1785-76)

^(c) Remote filter required.

Minimum Airflow CFM

A4AH6V24A1B30A		
Heater	Minimum Heater Airflow CFM	
	With Heat Pump	Without Heat Pump
BAYHTR1504BRK, BAYHTR1504LUG BAYHTR1505BRK, BAYHTR1505LUG	660	600
BAYHTR1508BRK, BAYHTR1508LUG	780	600
BAYHTR1510BRK, BAYHTR1510LUG	780	600
BAYHTR1517BRK	1050	850
BAYHTR3510LUG	780	600
BAYHTR3517LUG	900	850

A4AH6V24A1B30A Airflow Performance with Auxiliary Heat				
Airflow Settings	Dip Switch Settings		Nominal Airflow	See following tables for heater application: - Pressure Drop for Electrical Heaters - Minimum Heating Airflow Matrix (on unit nameplates)
	Switch 7	Switch 8		
Low	ON	ON	601	
Med-Lo	OFF	ON	661	
Med-Hi	ON	OFF	781	
High	OFF	OFF	973	

Heater Pressure Drop Table

Airflow CFM	Number of Racks				Heater Racks	
	1	2	3	4	Heater Model	No. of Racks
	Air Pressure Drop — Inches W.G.					
1800	0.02	0.04	0.06	0.14	BAYHTR1504	1
1700	0.02	0.04	0.06	0.14	BAYHTR1505	1
1600	0.02	0.04	0.06	0.13	BAYHTR1508	2
1500	0.02	0.04	0.06	0.12	BAYHTR1510	2
1400	0.02	0.04	0.06	0.12	BAYHTR1517	3
1300	0.02	0.04	0.05	0.11	BAYHTR3510	3
1200	0.01	0.04	0.05	0.10	BAYHTR3517	3
1100	0.01	0.03	0.05	0.09	BAYHTR3515	3
1000	0.01	0.03	0.04	0.09	BAYHTR1523	4
900	0.01	0.03	0.04	0.08	BAYHTR1525	4
800	0.01	0.03				
700	0.01	0.02				
600	0.01	0.02				

Subcooling Adjustment

System Matched with:	Indoor Unit Model No.	Outdoor Model No.	Subcooling
16 SEER HP — 2 ton	A4AH6V36A1C30	4TWR6024H1 4TWX6024H1 4A6H6024H1 A4HP6024A1	13 Degrees
15 SEER HP — 2 ton	A4AH6V24A1B30 A4AH6V30A1B30	4TWR5024G1 4A6H5024G1 A4HP6024A1	14 Degrees
15 SEER HP — 3 ton	A4AH6V30A1B30 A4AH6V36A1C30 A4AH6V42A1C30	4TWR5036G1 4A6H5036G1 A4HP6036A1	14 Degrees
All other matches must be charged per the nameplate charging instructions			

Performance and Electrical Data

1. See Product Data or Air Handler nameplate for approved combinations of Air Handlers and Heaters.
2. Heater model numbers may have additional suffix digits.

Table 1. Air Flow Performance

A4AH6V24A1B30A COOLING AIRFLOW PERFORMANCE, WET COIL, NO FILTER, NO HEATER												
OUTDOOR UNIT SIZE (TONS)	SPEED SETTING	AIRFLOW SETTING	DIP SWITCH SETTING				AIRFLOW POWER	EXTERNAL STATIC PRESSURE				
			SW1	SW2	SW3	SW4		0.1	0.3	0.5	0.7	0.9
1.5	LOW	353 CFM/ton	ON	ON	OFF	ON	CFM Watts	533 52	497 78	461 104	425 130	390 157
	NORMAL	401 CFM/ton	ON	ON	OFF	OFF	CFM Watts	611 65	580 95	548 125	517 155	486 185
	HIGH	451 CFM/ton	ON	ON	ON	OFF	CFM Watts	684 81	668 115	644 148	611 182	570 215
2	LOW	343 CFM/ton	OFF	ON	OFF	ON	CFM Watts	687 82	672 115	648 149	614 182	571 215
	NORMAL	390 CFM/ton	OFF	ON	OFF	OFF	CFM Watts	789 104	798 145	780 183	735 216	663 246
	HIGH	439 CFM/ton	OFF	ON	ON	OFF	CFM Watts	884 135	887 177	882 230	845 274	751 290
2.5	LOW	300 CFM/ton	ON	OFF	OFF	ON	CFM Watts	752 92	749 123	729 167	691 211	636 241
	NORMAL ^(a)	340 CFM/ton	ON	OFF	OFF	OFF	CFM Watts	859 128	861 172	863 211	830 242	727 268
	HIGH	383 CFM/ton	ON	OFF	ON	OFF	CFM Watts	963 172	973 223	995 263	967 291	844 308

^(a) Factory Default Setting

Table 2. Air Flow Performance

A4AH6V24A1B30A HEATING AIRFLOW PERFORMANCE, NO FILTER, NO HEATER												
OUTDOOR UNIT SIZE (TONS)	SPEED SETTING	AIRFLOW SETTING	DIP SWITCH SETTING				AIRFLOW POWER	EXTERNAL STATIC PRESSURE				
			SW1	SW2	SW3	SW4		0.1	0.3	0.5	0.7	0.9
1.5	LOW	394 CFM/ton	ON	ON	OFF	ON	CFM Watts	599 58	571 88	539 117	502 146	462 175
	NORMAL	448 CFM/ton	ON	ON	OFF	OFF	CFM Watts	680 72	665 109	641 145	610 178	572 209
	HIGH	493 CFM/ton	ON	ON	ON	OFF	CFM Watts	748 89	746 118	682 163	545 208	326 240
2	LOW	393 CFM/ton	OFF	ON	OFF	ON	CFM Watts	785 97	790 128	773 175	735 223	674 253
	NORMAL	446 CFM/ton	OFF	ON	OFF	OFF	CFM Watts	904 131	902 179	912 219	894 253	809 281
	HIGH	491 CFM/ton	OFF	ON	ON	OFF	CFM Watts	980 167	972 216	990 268	974 308	863 324
2.5	LOW	350 CFM/ton	ON	OFF	OFF	ON	CFM Watts	866 125	870 162	866 215	833 263	750 286
	NORMAL ^(a)	398 CFM/ton	ON	OFF	OFF	OFF	CFM Watts	995 171	988 222	1005 271	986 309	872 325
	HIGH	437 CFM/ton	ON	OFF	ON	OFF	CFM Watts	1099 220	1086 274	1098 328	1065 362	918 353

^(a) Factory Default Setting

Performance and Electrical Data

Table 3. Electrical Data

A4AH6V24A1B30A HEATER DATA											
Heater Model No.	No. of Circuits/ Phases	240 Volt					208 Volt				
		Capacity		Heater Amps per Circuit	Minimum Circuit Ampacity	Maximum Overload Protection	Capacity		Heater Amps per Circuit	Minimum Circuit Ampacity	Maximum Overload Protection
		kW	BTUH				kW	BTUH			
No Heater				2.5 *	3	15			2.5 *	3	15
BAYHTR1504BRK BAYHTR1504LUG	1/1	3.84	13100	16.0	23	25	2.88	9800	13.8	20	20
BAYHTR1505BRK BAYHTR1505LUG	1/1	4.80	16400	20.0	28	30	3.60	12300	17.3	25	25
BAYHTR1508BRK BAYHTR1508LUG	1/1	7.68	26200	32.0	43	45	5.76	19700	27.7	38	40
BAYHTR1510BRK BAYHTR1510LUG	1/1	9.60	32800	40.0	53	60	7.20	24600	34.6	46	50
BAYHTR1517BRK Circuit 1 ^(a)	2/1	9.60	32800	40.0	53	60	7.20	24600	34.6	46	50
BAYHTR1517BRK Circuit 2		4.80	16400	20.0	25	25	3.60	12300	17.3	22	25
BAYHTR3510LUG	1/3	9.60	32800	23.1	32	35	7.20	24600	20.0	28	30
BAYHTR3517LUG	1/3	14.40	49100	34.6	46	50	10.80	36900	30.0	40	45

* = Motor Amps

^(a) MCA and MOP for circuit 1 contains the motor amps

Features and Benefits

- Galvanized metal cabinet with captured foil face insulation
- 2% or less air leakage
- R-4.2 Insulating Value
- Multi-Position UP/Down Flow, Horizontal Left /Right
- ALL Aluminum Coil with Enhanced Patented Coil Fin
- Electric Heaters with polarized plug connections (sold as accessory)
- R-410A Thermal Expansion Valve
- Variable Speed ECM Motor
- Low Voltage Pigtail Connections
- Draw Through Design
- Horizontal Drain pan
- Single Color
- Fused 24V Power
- **5 year warranty**
- **Optional extended warranty available**

Important: Condensate management kit is required for all 5 ton air handler models installed in downflow applications.

About Trane and American Standard Heating and Air Conditioning

Trane and American Standard create comfortable, energy efficient indoor environments for residential applications. For more information, please visit www.trane.com or www.americanstandardair.com.



The manufacturer has a policy of continuous data improvement and it reserves the right to change design and specifications without notice. We are committed to using environmentally conscious print practices.