

TAG: _____

SUBMITTAL

18 SERIES

Specifications - IP

Single Zone Mini-Split
Inverter System

M4MHW1809A1N0B

M4THS1809A11NB

| MODEL - Heat Pump Only | M4MHW1809A1N0B / M4THS1809A11NB | |
|---|---------------------------------|--------------------|
| | Cooling | Heating |
| RATED Volts/PH | 208 / 230 / 1 | |
| Frequency (Hz) | 60Hz | |
| Rated Cooling / Heating Capacity (Btu/h): | 9000 | 11000 |
| Minimum Cooling Capacity (@95°F) (Btu/h): ② | 3100 | - |
| Maximum Cooling Capacity (@95°F) (Btu/h): ② | 9600 | - |
| Minimum Heating Capacity (@47°F) (Btu/h): ② | - | 1900 |
| Maximum Heating Capacity (@47°F) (Btu/h): ② | - | 12000 |
| Rated Heating Capacity (@17°F) (Btu/h): ② | - | 6800 |
| Total Capacity (W) (High/Standard/Low): | 2814/2638/908 | 3517/3224/560 |
| Nominal Power Input (W) | 630 | 1020 |
| Nominal Input Current (A) | 2.8 | 3.5 |
| SEER / HSPF | 18.0 | 10.5 |
| EER / COP (Btu/h)/W | 14.0 | 10.8 |
| Air Flow Volume (CFM) (H//M/L/QUIET) | 375/275/225/175 | |
| Dehumidifying Volume (pt./h) | 1.7 | |
| Indoor Unit | M4MHW1809A1N0B | |
| Fan Motor Speed (r/min) (H//M/L/QUIET) | 1350/1200/1050/750 | 1300/1150/1000/900 |
| Fan Motor RLA(A) | 0.09 | |
| Evaporator | Aluminum Fin-Copper Tube | |
| Pipe Diameter (inch) | 0.28 | |
| Rows - Fin Gap (inch) | 2 - 0.06 | |
| Coil length (L) x depth (D) x coil width (W) (inch) | 25 x 0.9 x 12.1 | |
| Output of Swing Motor (W) | 1.5 | |
| Fuse (A) | 3.15 | |
| Sound PRESSURE Level dB (A)(H//M/L/QUIET) ① | 43/39/35/29 | |
| Uncrated Dimension (W/H/D) (inch) | 33.3 x 11.4 x 8.2 | |
| Crated Dimension of Package (L/W/H) (inch) | 36.3 x 11.1 x 14.9 | |
| Net Weight /Gross Weight (lbs) | 22.1 / 26.5 | |
| Outdoor Unit | M4THS1809A11NB | |
| Compressor Type | Swing | |
| Compressor Oil Type | DAPHNE FVC50K (PVE Oil) | |
| Compressor RLA(A) | 4.0 | |
| Compressor Power Input(W) | 845 | |
| Throttling Method | EEV | |
| Working Temp Range (°F) | 0 ~ 115 | -4 ~ 75 |
| Condenser | Aluminum Fin-Copper Tube | |
| Pipe Diameter (inch) | 0.38 | |
| Rows - Fin Gap (inch) | 2 - 0.06 | |
| Coil length (L) x depth (D) x coil width (W) (inch) | 29.4 x 1.7 x 20 | |
| Fan Motor Speed (rpm) | 900 | |
| Output of Fan Motor (W) | 30 | |
| Fan Motor RLA (A) | 0.36 | |
| Air Flow Volume of Outdoor Unit (CFM) | 623 | |
| Fan Diameter (inch) | 15.8 | |
| Defrosting Method | Automatic Defrosting | |
| Sound PRESSURE Level dB (A)① | 53 | |
| Uncrated Dimension (W/H/D) (inch) | 33.4 x 21.3 x 12.6 | |
| Crated Dimension of Package (L/W/H) (inch) | 34.7 x 14.3 x 23.4 | |
| Net Weight /Gross Weight (lbs) | 78.3 / 83.8 | |
| Refrigerant Charge (oz) | 46 | |
| MCA | 9 | |
| MOP | 15 | |
| Connection Pipe | | |
| Gas additional charge(oz/ft) | 0.22 | |
| Outer Diameter Liquid Pipe (inch) | 1/4 | |
| Outer Diameter Gas Pipe (inch) | 3/8 | |
| Max Height Distance (ft) | 55 | |
| Max Length Distance (ft) | 100 | |

① Sound PRESSURE Level @ 3.3 ft. dB(A)
② Capacities based on fixed compressor speed
AHRI validation testing

Specifications - SI

MODEL - Heat Pump Only

M4MHW1809A1N0B / M4THS1809A11NB

| | Cooling | Heating |
|--|-----------------|---------------|
| RATED Volts/PH | 208 / 230 / 1 | |
| Frequency (Hz) | 60Hz | |
| Rated Cooling / Heating Capacity (Btu/h): | 9000 | 11000 |
| Minimum Cooling Capacity (@35°C) (Btu/h): ② | 3100 | - |
| Maximum Cooling Capacity (@35°C) (Btu/h): ② | 9600 | - |
| Minimum Heating Capacity (@8.3°C) (Btu/h): ② | - | 1900 |
| Maximum Heating Capacity (@8.3°C) (Btu/h): ② | - | 12000 |
| Rated Heating Capacity (@-8.3°C) (Btu/h): ② | - | 6800 |
| Total Capacity (W) (High/Standard/Low): | 2814/2638/908 | 3517/3224/560 |
| Nominal Power Input (W) | 630 | 1020 |
| Nominal Input Current (A) | 2.8 | 3.5 |
| SEER / HSPF | 18.0 | 10.5 |
| EER / COP (Btu/h)/W | 14.0 | 10.8 |
| Air Flow Volume (m³/h) (H/M/L/QUIET) | 640/490/410/290 | |
| Dehumidifying Volume (L/h) | 0.80 | |

Indoor Unit

M4MHW1809A1N0B

| | | |
|---|--------------------------|--------------------|
| Fan Motor Speed (r/min) (H/M/L/QUIET) | 1350/1200/1050/750 | 1300/1150/1000/900 |
| Fan Motor RLA(A) | 0.09 | |
| Evaporator | Aluminum Fin-Copper Tube | |
| Pipe Diameter (mm) | φ 7 | |
| Rows - Fin Gap (mm) | 2 - 1.4 | |
| Coil length (L) x depth (D) x coil width (W) (mm) | 635×22.8×306.3 | |
| Output of Swing Motor (W) | 1.5 | |
| Fuse (A) | 3.15 | |
| Sound PRESSURE Level dB (A)(H/M/L/QUIET) ① | 43/39/35/29 | |
| Uncrated Dimension (W/H/D) (mm) | 845×289×209 | |
| Crated Dimension of Package (L/W/H) (mm) | 921×281×379 | |
| Net Weight /Gross Weight (kg) | 10 / 12 | |

Outdoor Unit

M4THS1809A11NB

| | | |
|---|--------------------------|----------|
| Compressor Type | Swing | |
| Compressor Oil Type | DAPHNE FVC50K (PVE Oil) | |
| Compressor RLA(A) | 4.0 | |
| Compressor Power Input(W) | 845 | |
| Throttling Method | EEV | |
| Working Temp Range (°C) | -18 ~ 46 | -20 ~ 24 |
| Condenser | Aluminum Fin-Copper Tube | |
| Pipe Diameter (mm) | φ 9.5 | |
| Rows - Fin Gap (mm) | 2 - 1.4 | |
| Coil length (L) x depth (D) x coil width (W) (mm) | 747×44×508 | |
| Fan Motor Speed (rpm) | 900 | |
| Output of Fan Motor (W) | 30 | |
| Fan Motor RLA (A) | 0.36 | |
| Air Flow Volume of Outdoor Unit (m³/h) | 1059 | |
| Fan Diameter (mm) | 400 | |
| Defrosting Method | Automatic Defrosting | |
| Sound PRESSURE Level dB (A)① | 53 | |
| Uncrated Dimension (W/H/D) (mm) | 848×540×320 | |
| Crated Dimension of Package (L/W/H) (mm) | 881×363×595 | |
| Net Weight /Gross Weight (kg) | 35.5 / 38 | |
| Refrigerant Charge (kg) | 1.3 | |
| MCA | 9 | |
| MOP | 15 | |

Connection Pipe

| | |
|---------------------------------|-------|
| Gas additional charge(g/m) | 20 |
| Outer Diameter Liquid Pipe (mm) | φ 6 |
| Outer Diameter Gas Pipe (mm) | φ 9.5 |
| Max Height Distance (m) | 17 |
| Max Length Distance (m) | 30 |

① Sound PRESSURE Level @ 1m dB(A)

② Capacities based on fixed compressor speed AHRI validation testing

Unit Dimensions

9K Indoor Units

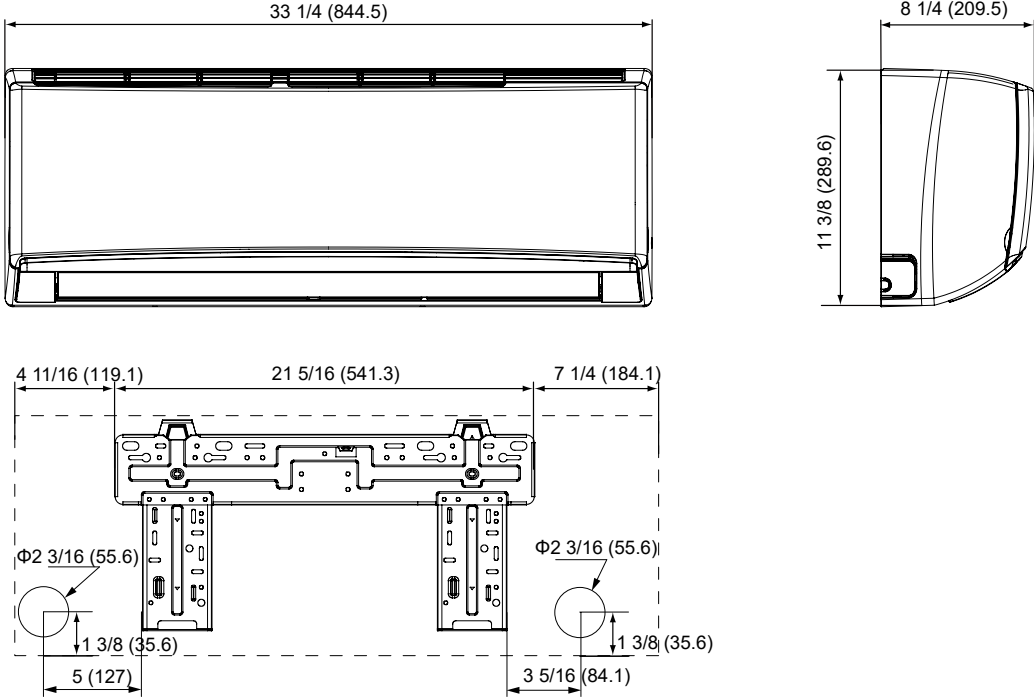

Unit: inch (mm)

9K Outdoor Units

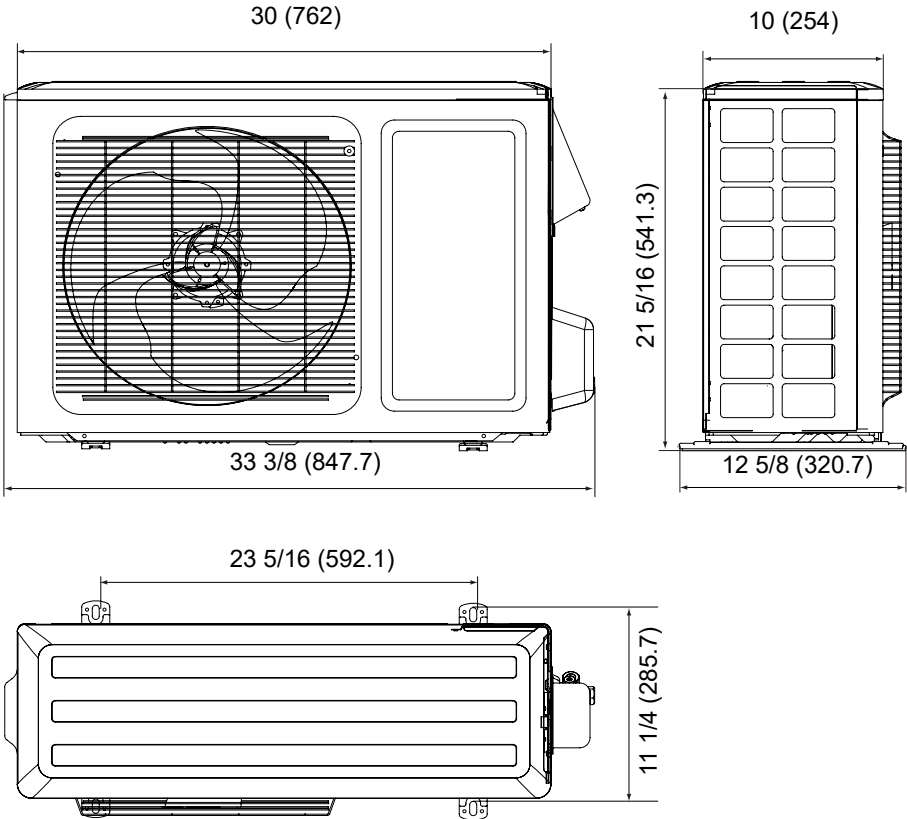

Performance Data

M4THS1809A11NB/M4MHW1809A1NOB - Cooling Mode Performance Data

| Outdoor Ambient Air Temperature (°F) | Indoor Entering Air Temperature (Dry Bulb/Wet Bulb) | | | | | | | |
|--------------------------------------|---|-------|---------|------|---------|------|---------|------|
| | 68/57°F | | 73/61°F | | 80/67°F | | 82/68°F | |
| | TC* | SHC** | TC | SHC | TC | SHC | TC | SHC |
| 5 | 6300 | 4900 | 6600 | 5200 | 7600 | 5900 | 7900 | 6200 |
| 15 | 6900 | 5400 | 7300 | 5800 | 8400 | 6600 | 8800 | 6900 |
| 25 | 8400 | 6600 | 8900 | 7000 | 9700 | 7600 | 10600 | 8300 |
| 35 | 9200 | 7200 | 9800 | 7700 | 10400 | 8200 | 11200 | 8800 |
| 45 | 9000 | 7100 | 9600 | 7500 | 10300 | 8100 | 11000 | 8600 |
| 55 | 8800 | 6900 | 9300 | 7300 | 10200 | 8000 | 10900 | 8500 |
| 65 | 8500 | 6700 | 9100 | 7100 | 10000 | 7800 | 10700 | 8400 |
| 75 | 8200 | 6500 | 8800 | 6900 | 9700 | 7600 | 10500 | 8300 |
| 85 | 8000 | 6300 | 8600 | 6700 | 9500 | 7400 | 10300 | 8100 |
| 95 | 7800 | 6100 | 8400 | 6600 | 9400 | 7300 | 10100 | 7900 |
| 105 | 7600 | 5900 | 8100 | 6400 | 9100 | 7200 | 9900 | 7700 |
| 115 | 7400 | 5800 | 7900 | 6200 | 8900 | 7000 | 9600 | 7500 |
| 125 | 7100 | 5600 | 7600 | 5900 | 8500 | 6700 | 9300 | 7300 |

*Total Capacity **Sensible Heat Capacity

M4THS1809A11NB/M4MHW1809A1NOB - Heating Mode Performance Data

| Outdoor Ambient Air Temperature (°F) | Indoor Entering Air Temperature | | | |
|--------------------------------------|---------------------------------|-------|-------|-------|
| | 68°F | 73°F | 80°F | 82°F |
| | TC* | TC | TC | TC |
| 0 | 8900 | 8800 | 8600 | 8600 |
| 5 | 9900 | 9800 | 9600 | 9500 |
| 10 | 10300 | 10200 | 10000 | 9900 |
| 15 | 10800 | 10600 | 10400 | 10300 |
| 20 | 11400 | 11300 | 11100 | 11000 |
| 25 | 11600 | 11500 | 11200 | 11100 |
| 30 | 11900 | 11800 | 11600 | 11500 |
| 35 | 12200 | 12100 | 11800 | 11700 |
| 40 | 12300 | 12200 | 12000 | 11800 |
| 45 | 12400 | 12300 | 12100 | 12000 |
| 50 | 12600 | 12500 | 12200 | 12100 |
| 55 | 12700 | 12600 | 12300 | 12200 |
| 60 | 12800 | 12700 | 12400 | 12300 |
| 65 | 12900 | 12800 | 12600 | 12400 |
| 70 | 13000 | 12900 | 12700 | 12500 |
| 75 | 13200 | 13000 | 12800 | 12700 |
| 80 | 13400 | 13300 | 13000 | 12900 |

*Total Capacity

Capacities in these performance tables reflect normal operation at the temperatures indicated. See specification tables above for certified values under prescribed test conditions.

Application Area/Air Throw for High Wall

| Model | Application Area | Cooling Mode | Heating Mode |
|-----------|-------------------------------------|--------------|--------------|
| M4MHW1809 | 129-194 sf. (12-18 m ²) | 29.5 (9) | 23 (7) |

Unit: ft. (m)

Mechanical Specifications

Single Zone Outdoor Unit

General

This unit shall be fully charged from the factory for 25 feet (7.6m) of piping. This unit is designed to operate at outdoor ambient temperatures as high as 115°F (46°C). Cooling capacities with the mini-split air handler shown in the catalog are AHRI certified. The unit is ETL listed for outdoor application.

Unit Casing

The unit casing shall be constructed of heavy gauge, galvanized steel and painted with a weather-resistant powder paint.

Refrigerant Controls

Refrigeration system controls include condenser fan and compressor relay. High and low pressure controls are inherent to the compressor. A suction line multi function service valve is standard

Compressor

The compressor features internal over temperature and pressure protection; total dipped hermetic motor windings. Other features include: centrifugal oil pump and low vibration and noise.

Condenser Coil

The coil shall consist of aluminum finned coils brazed to copper tubing. The coil provides airflow resistance and efficient heat transfer. The coil is protected by the casing.

Low Ambient Cooling

Matched 18 Series Energy Star® duct-less products, have a cooling capability to 0°F (-18°C) and heating capability to -4°F (-20°C).

Single Zone Indoor High Wall

General

The High Wall mounted type air handler shall be completely factory assembled including coil, condensate drain pan, fan motor, washable filter, air purifying filter and electric controls to be used with a wireless remote controller. Unit shall be shipped with a unit mounting plate. Unit shall be matched with a 18 Series Energy Star® outdoor unit, rated and tested in accordance with AHRI standard. Unit shall be ETL listed.

Unit Casing

Casing shall be provided with knockouts on the right, and left of the unit to facilitate piping and electrical connection on either side of the unit. An electrical service cover shall be provided to permit easy access to the electrical terminal strip.

Discharge Airflow and Distribution System

Unit shall have auto swing, dual horizontal blades to optimize the aperture outlet for vertical airflow and air distribution. Blade shall close automatically when the air conditioner is turned off to minimize dust entering the unit. Five-Step preset program on the remote controller shall be available to control the blade angle.

Manually adjusted wide-angle louvers shall be provided to adjust the coverage and direction of airflow.

Controls

Units shall have the capability to be controlled remotely.

Remote Controller

The unit shall have an optional wireless infrared remote controller with an easily readable digital display panel to start, stop and regulate the air conditioner from a distance.

The wireless controller is included with all units.

Healthy Filters

The unit shall have one combined active carbon and catechin filter with the unit. The filter needs to be cleaned at least once a year.

About Trane and American Standard Heating and Air Conditioning

Trane and American Standard create comfortable, energy efficient indoor environments for residential applications. For more information, please visit www.trane.com or www.americanstandardair.com



The AHRI Certified mark indicates company participation in the AHRI Certification program. For verification of individual certified products, go to ahridirectory.org.

The manufacturer has a policy of continuous data improvement and it reserves the right to change design and specifications without notice. We are committed to using environmentally conscious print practices.